

LATTICE SUSPENDED BAFFLES

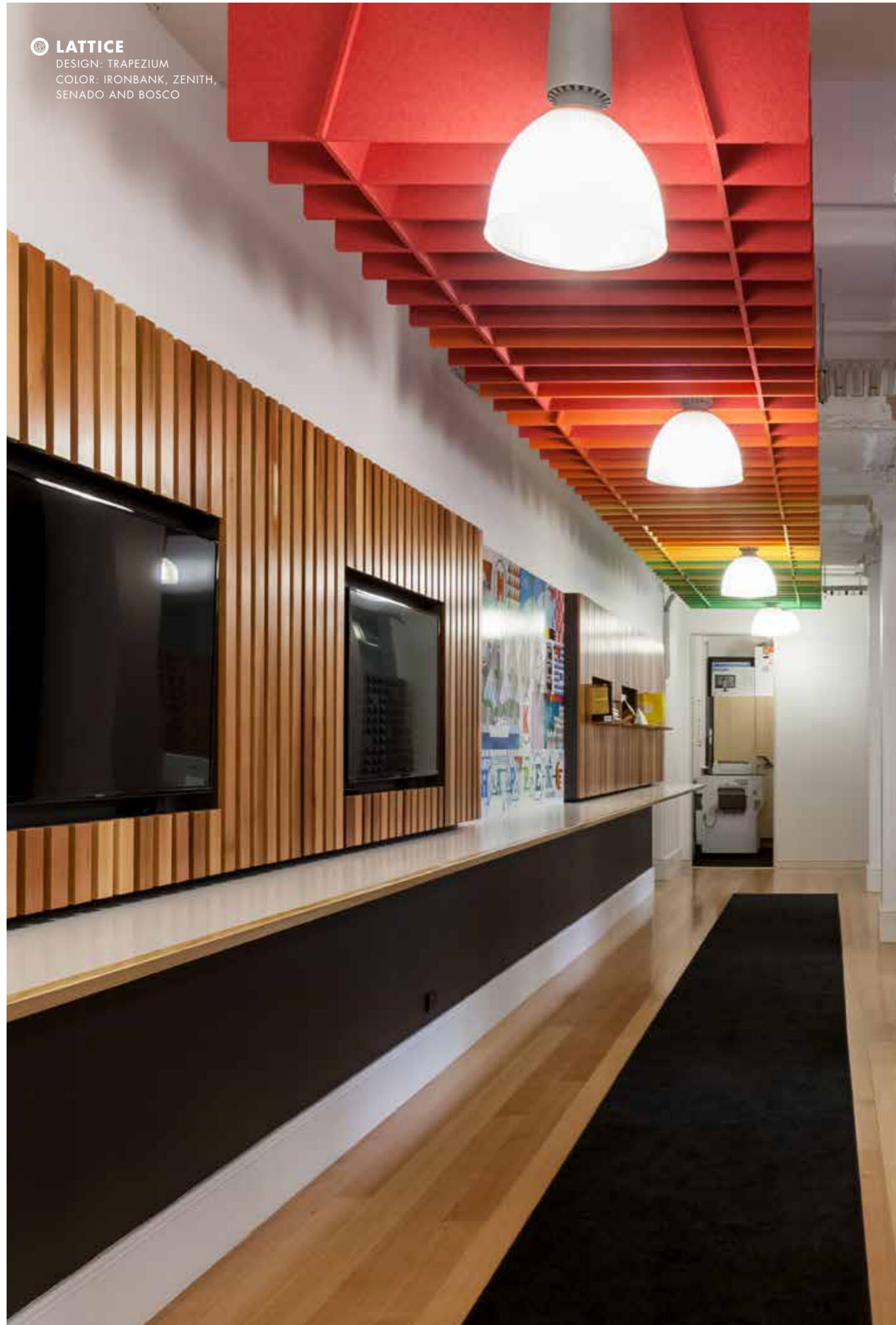

LATTICE
DESIGN: TRAPEZIUM
COLOR: IRONBANK, ZENITH,
SENADO AND BOSCO



LATTICE

Lattice is a master at controlling the echo of background chatter and reducing reverberated noise whilst adding a unique piece to any space.

Lattice offers incredible performance by using fins. Because noise operates in different frequencies the various shapes of Lattice are designed to tune into and cut out the babble. Lattice is available in 3 ready to go styles but our design team can create bespoke fins and shapes for your challenge. Lattice is available in a wide range of colors.

But Lattice doesn't only look good, it's high performing as well; specifically designed to reduce and control echo creating a more focused and productive space.

Just like the rest of our range, durability, longevity and performance are assured, leaving nothing left but your creative license.

LATTICE

APPLICATIONS

- Decorative and functional acoustic absorption system for office, education, retail, hospitality and commercial interiors
- Minimize noise in the interior environment and create a unique aesthetic

SPECIFICATION

Suspended acoustic absorption system shall be Lattice from thermally bonded polyester containing not less than 45% recycled material as manufactured by Autex. www.autexindustries.com

Suspended acoustic absorber Autex Eclipse / Autex Torus / Autex Trapezium, color (L), sound absorption Class A, NRC 1.00 – if direct fixed to ceiling: Class A, NRC 1.00. Fire rating ASTM E-84-14: Class A, FS:0 - SD:45, ISO 9705: Classification: Group 1-S, AS ISO 9705 – 2003, Classification: Group 1, EN13501-1:2007+A1:2009: B-s2, d2.

Lattice to be supplied unassembled with 4 x 39" galvanised cables, 4 x ceiling mounts, 4 x "Velda" cable clips, 4 x alloy tube inserts. Install as per Autex Lattice (Eclipse, torus, trapezium) Install Instructions.

Suspended acoustic absorber 57.1" x 57.1" x 11.54" (nom. depth), color (L). Fire rating ASTM E-84-15a: Class A, FS:0 - SD:45, ISO 9705: Classification: Group 1-S, AS ISO 9705 – 2003. Classification: Group 1, EN1350-1: 2007 + A1: 2009: B-s2, d2.

Lattice to be supplied unassembled with 8 x 39" galvanised cables, 8 x ceiling mounts, 8 x "Velda" cable clips. Install as per Autex Lattice Install Instructions.



LATTICE DESIGN OPTIONS

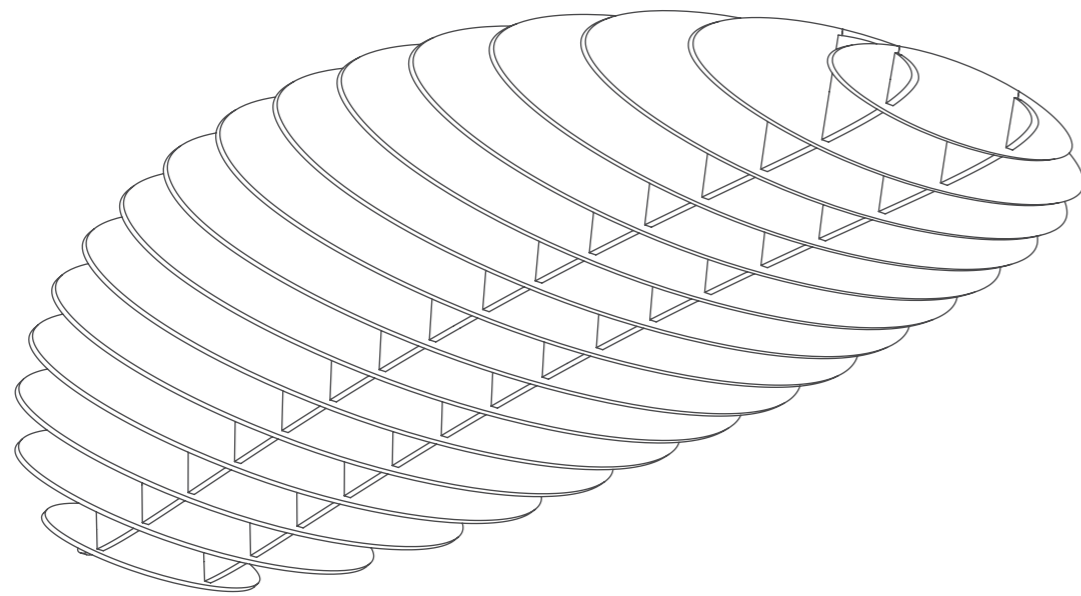

DESIGN ECLIPSE COLOR SEE PAGE 17 FOR FULL COLOR RANGE

EQUIVALENT ABSORPTION AREA ACCORDING TO ISO 354

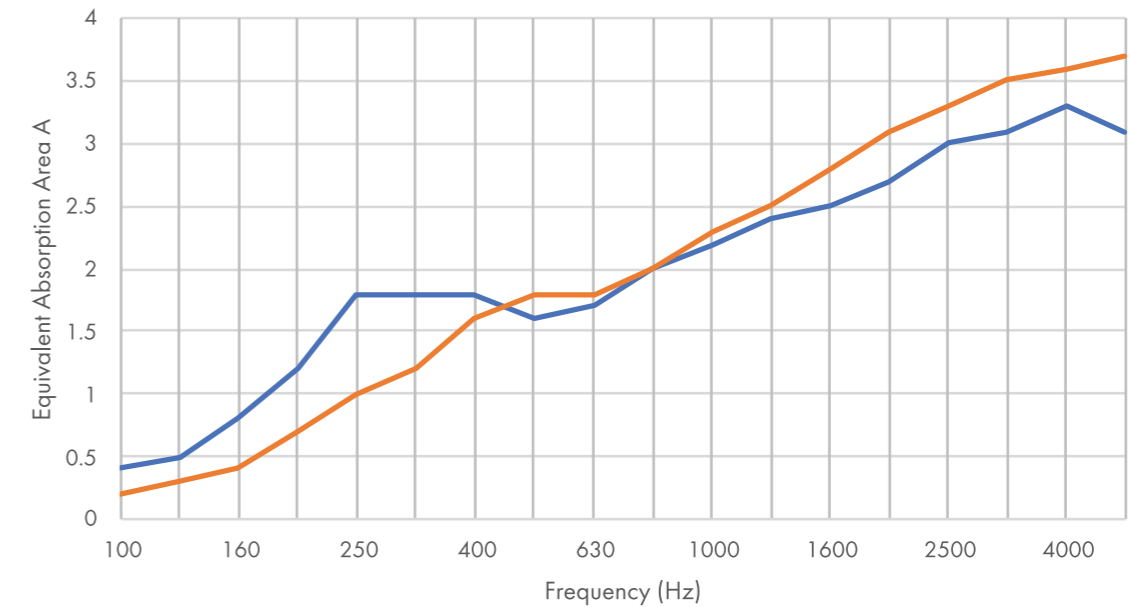

Frequency (Hz)	University of Auckland Test Report Number	125	250	500	1000	2000	4000	Metric Sabine Per Unit
Lattice Eclipse 1/2" Direct Fix	T1420-1	0.6	1.6	1.7	2.2	2.8	3.2	2.10
Lattice Eclipse 1/2" Suspended 7.87"	T1409-7	0.3	1.0	1.8	2.3	3.1	3.6	2.05

All results are reported in Metric Sabine - per unit. Equivalent sound absorption area according to ISO 354 Measurement of sound absorption in a reverberation room. Average Absorption (Sabins per unit) calculated at one-third octave bands centred on 250 Hz, 500 Hz, 1000 Hz and 2000 Hz, and rounded to the nearest 0.05.

PRODUCT SPECIFICATIONS

Product Name	Lattice Eclipse
Composition	100% Polyester Fibre (PET)
Assembled Size	47.1" x 92.4" x 13.3"
Tolerance	(+0.02") (+0.02") (+0.02")
Thickness	1/2"
Tolerance	(+/-6%)
Weight	7.54 oz/ft ²

INSTALLATION

Install as per Autex recommendations. Install instructions are included in each pack or available on the website.

ACOUSTIC PERFORMANCE

Lattice Eclipse is specifically designed to reduce and control reverberated noise (echo) in building interiors.

LIGHT REFLECTANCE VALUES BY COLOR

Lattice is suitable for indoor use only. LRVs were measured in accordance with BS 8493:2008+A1:2010

Pavilion	78	Zenith	22
Opera	49	Lotus	16
Savoye	47	Galaxy	16
Senado	45	Iron Bank	13
Rosada	45	Pinnacle	8
Acros	42	Empire	6
Falling Water	36	Tree House	3
Bosco	29	Petronas	2
Flatiron	25		

LATTICE

DESIGN OPTIONS

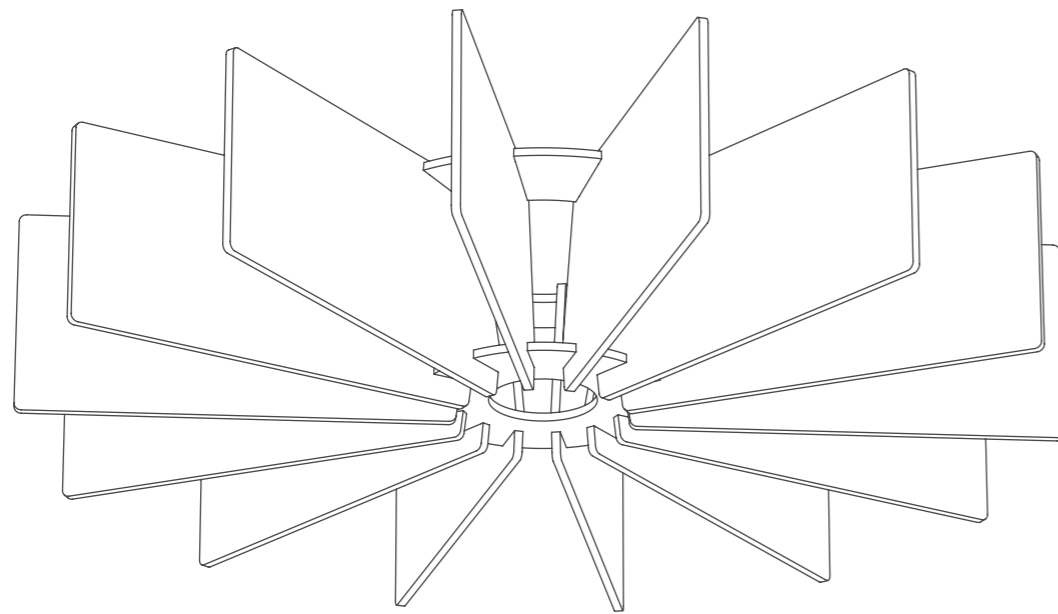

DESIGN TORUS COLOR SEE PAGE 17 FOR FULL COLOR RANGE

EQUIVALENT ABSORPTION AREA ACCORDING TO ISO 354

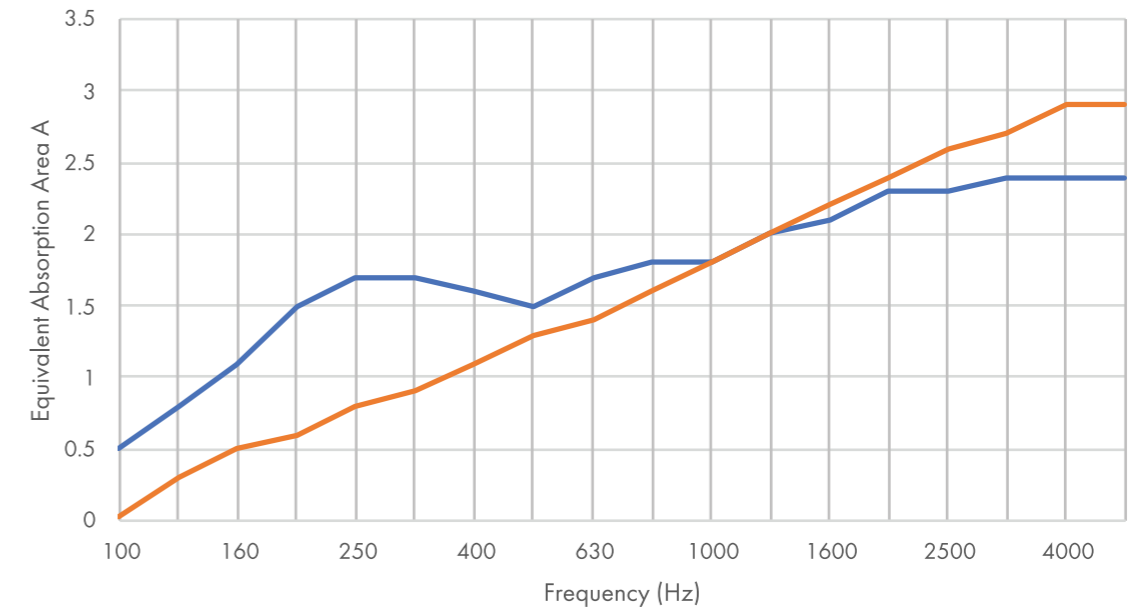

Frequency (Hz)	University of Auckland Test Report Number	125	250	500	1000	2000	4000	Metric Sabine Per Unit
Lattice Torus 1/2" Direct Fix	T1420-2	0.8	1.7	1.6	1.9	2.3	2.4	1.85
Lattice Torus 1/2" Suspended 7.87"	T1420-2	0.3	0.8	1.3	1.8	2.4	2.9	1.60

All results are reported in Metric Sabine - per unit. Equivalent sound absorption area according to ISO 354 Measurement of sound absorption in a reverberation room. Average Absorption (Sabins per unit) calculated at one-third octave bands centred on 250 Hz, 500 Hz, 1000 Hz and 2000 Hz. and rounded to the nearest 0.05.

PRODUCT SPECIFICATIONS

Product Name	Lattice Torus
Composition	100% Polyester Fibre (PET)
Assembled Size	57.1" x 57.1" x 11.5"
Tolerance	(+0.02") (+0.02") (+0.02")
Thickness	1/2"
Tolerance	(+/-6%)
Weight	7.54 oz/ft ²

INSTALLATION

Install as per Autex recommendations. Install instructions are included in each pack or available on the website.

ACOUSTIC PERFORMANCE

Lattice Torus is specifically designed to reduce and control reverberated noise (echo) in building interiors.

LIGHT REFLECTANCE VALUES BY COLOR

Lattice is suitable for indoor use only. LRVs were measured in accordance with BS 8493:2008+A1:2010

Pavilion	78	Zenith	22
Opera	49	Lotus	16
Savoye	47	Galaxy	16
Senado	45	Iron Bank	13
Rosada	45	Pinnacle	8
Acros	42	Empire	6
Falling Water	36	Tree House	3
Bosco	29	Petronas	2
Flatiron	25		

LATTICE DESIGN OPTIONS

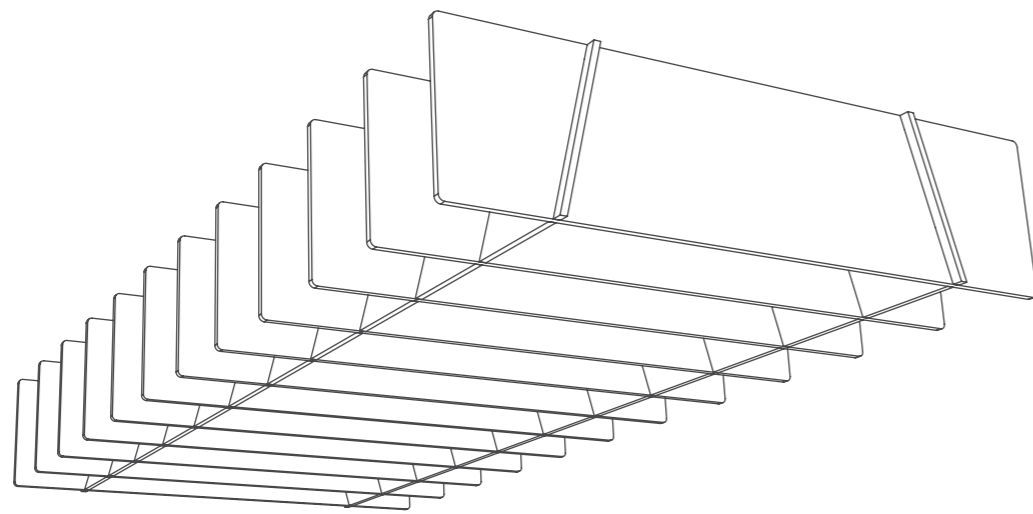

DESIGN TRAPEZIUM COLOR SEE PAGE 17 FOR FULL COLOR RANGE

EQUIVALENT ABSORPTION AREA ACCORDING TO ISO 354

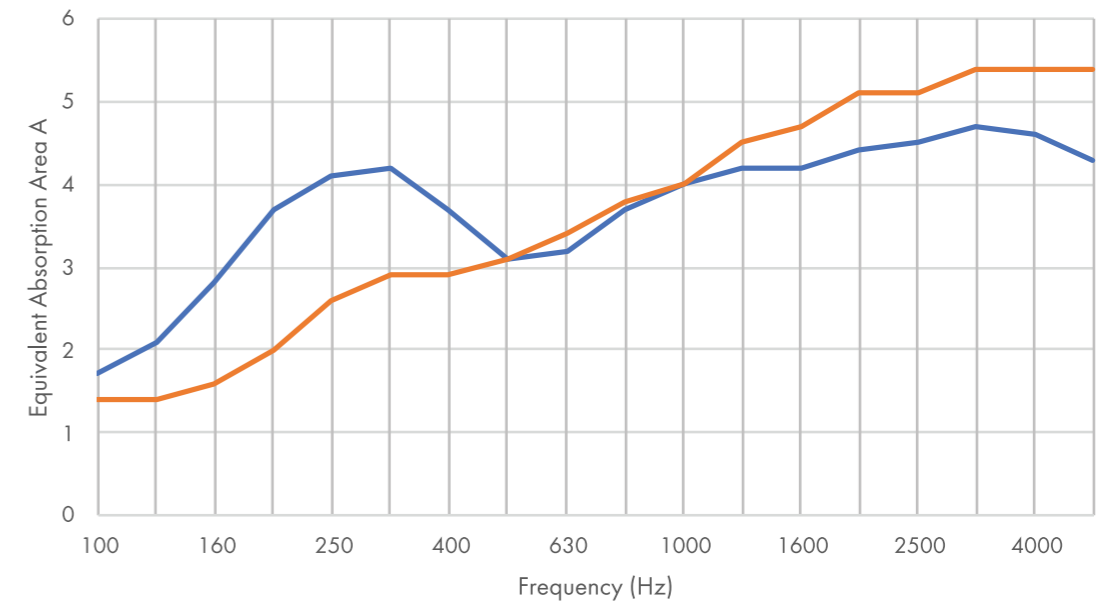

Frequency (Hz)	University of Auckland Test Report Number	125	250	500	1000	2000	4000	Metric Sabine Per Unit
Lattice Trapezium 1/2" Direct Fix	T1326-16	2.2	4.0	3.4	4.0	4.4	4.6	3.90
Lattice Trapezium 1/2" Suspended 7.87"	T1326-14	1.5	2.5	3.2	4.1	5.0	5.4	3.70

All results are reported in Metric Sabine - per unit. Equivalent sound absorption area according to ISO 354 Measurement of sound absorption in a reverberation room. Average Absorption (Sabins per unit) calculated at one-third octave bands centred on 250 Hz, 500 Hz, 1000 Hz and 2000 Hz, and rounded to the nearest 0.05.

PRODUCT SPECIFICATIONS

Product Name	Lattice Trapezium
Composition	100% Polyester Fibre (PET)
Assembled Size	47.1" x 92.4" x 13.3"
Tolerance	(+0.02") (+0.02") (+0.02")
Thickness	1/2"
Tolerance	(+/-6%)
Weight	7.54 oz/ft ²

INSTALLATION

Install as per Autex recommendations. Install instructions are included in each pack or available on the website.

ACOUSTIC PERFORMANCE

Lattice Trapezium is specifically designed to reduce and control reverberated noise (echo) in building interiors.

LIGHT REFLECTANCE VALUES BY COLOR

Lattice is suitable for indoor use only. LRVs were measured in accordance with BS 8493:2008+A1:2010

Pavilion	78	Zenith	22
Opera	49	Lotus	16
Savoye	47	Galaxy	16
Senado	45	Iron Bank	13
Rosada	45	Pinnacle	8
Acros	42	Empire	6
Falling Water	36	Tree House	3
Bosco	29	Petronas	2
Flatiron	25		

LATTICE
DESIGN: CUSTOM
COLOR: FLATIRON



FIRE RATINGS

Lattice is a value-added product made from Autex Cube™ acoustic panels as the base material. Cube™ (12mm) has been evaluated using the following test methods:

ISO 9705: 1993

Classification: Group 1-S
Smoke Production Rate: <5.0m²/s
As required by NZBC C/VM2

AS ISO 9705 - 2003

Classification: Group 1
(SMOGRARC): <100m²/s²
Assessed using methodology AS ISO 9705 - 2003 in accordance with AS 5637.1:2015, as required by BCA Specification C1.104
FI 4974 dated 16th September, 2012 and FAR 4055-2 dated 8th October 2013

EN13501-1:2007+A1:2009

B - s2, d2
WF336911 dated 25th February 2014

ASTM E-84-15a

Class A, FS:0 - SD:45
RJ4479-2 dated 25th January, 2015

VOC EMISSIONS

Autex polyester has been tested for chemical emissions in accordance with ASTM D5116 and is considered as a low VOC product.

VOC concentration: 0.009 mg/m³ (7 days)

WATER VAPOR SORPTION

ASTM C1104 / C1104M-13a

Test conditions: 49°C, 95%RH

Water vapor absorbed and adsorbed after 4 days: 0.4% by weight

MICROBIAL RESISTANCE

ASTM G21-15

Growth Rating: 0 (No growth)

Lattice Eclipse does not promote the growth of moulds and mildew.

COLOR FASTNESS TO LIGHT

Lattice is suitable for indoor use only. Light fastness is dependent on use and exposure. Lattice Eclipse has been evaluated to the following standard:

ISO 105-B02:2014

Rating: 6 (Highest = 7)

COLOR FASTNESS TO RUBBING

ISO 105-X12:2016

Dry Rating: 4-5 (Highest = 5)

Wet Rating: 4-5 (Highest = 5)

PATTERN REPEAT

Non-woven. No pattern repeat but product has directional grain. Product may vary from samples and batch to batch due to fibre blending and lay-up which is an inherent feature of this product.

FABRIC CARE

Blot spills from fabric quickly. Wipe with a damp cloth. Avoid rubbing and excessive amounts of water as this will affect the finish. Use carpet or upholstery shampoo as directed. Blot with a clean dry cloth after each application of solution.

Custom printed Cube™ requires the services of a specialist cleaning company.

Refer to the Lattice Cleaning and Maintenance Guide for more information.

ENVIRONMENTAL

Autex is committed to best practice through our ISO 9001 and ISO 14001 certified Quality and Environmental Management Systems.

Lattice contains a minimum of 45% previously recycled polyester fibre (from PET bottle-flake). Off-cuts and manufacturing waste are re-used or recycled wherever possible.

Lattice is manufactured from 100% polyester fibres and does not contain formaldehyde binders. Autex polyester fibres support safer indoor air quality and will not become a potential airborne pollutant.

SERVICE

For further information about Lattice Eclipse, Autex Cube™ or any other Autex product, please contact your Autex account manager or visit our website.

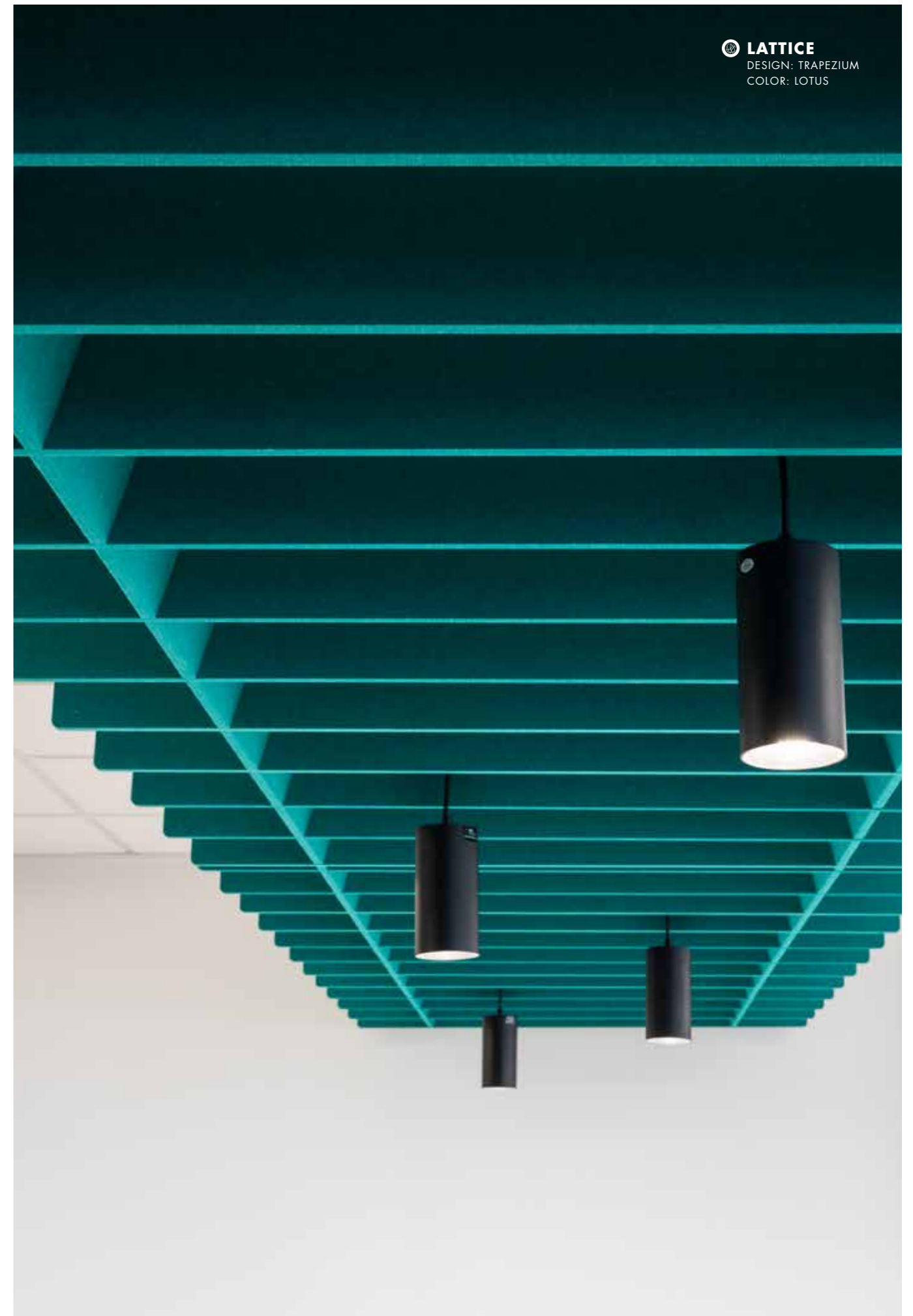

LATTICE
 DESIGN: ECLIPSE
 COLOR: FLATIRON,
 FALLING WATER,
 PINNACLE AND ZENITH



COLOR OPTIONS



MOQ's apply to some colors. To find out more, or to order a sample, please contact your Account Manager or visit our website.



CARING FOR THE ENVIRONMENT

Lattice is manufactured using 100% polyester fibre and contains a minimum of 45% recycled fibre (from PET plastics). Our products are designed to be recycled at the end of their life too.

We have continual improvement programmes in which we implement a range of initiatives to mitigate the environmental 'hotspots' that we have identified. Our products are GreenRate Level A, LCARate Gold and PHD level platinum certified.

Lattice is made from Cube™ which is Declaresm certified to be Red List free and can be used in Living Building Challenge projects. Autex has a high functioning Environmental Management System (ISO 14001) to enhance our environmental performance and contribute to sustainable development.



Declare.



**Autex Acoustics
Asia Sdn. Bhd**

03-05, Indah Walk 3,
Japan Indah 15,
Taman Bukit Indah,
79100, Iskandar Puteri,
Johor

www.autexacoustics.asia

Autex Industries Ltd

702-718 Rosebank Rd,
Private Bag 19988,
Avondale 1746, Auckland,
New Zealand
Freephone **0800 428 839**
Phone **+64 9 828 9179**
Fax **+64 9 828 5810**

www.autex.co.nz

Autex Australia Pty Ltd

166 Barnfield Road,
PO Box 5099,
West Heidelberg, Melbourne,
VIC 3081, Australia
Freephone **1800 678 160**
Phone **+61 3 9457 6700**
Fax **+61 3 9457 1020**

www.autex.com.au

Autex Acoustics Ltd

Unit J4, Lowfields Way,
Lowfields Business Park,
Eland, West Yorkshire,
Hx5 9Da,
United Kingdom
Phone **+44 (0) 1422 418899**

www.autexacoustics.co.uk

Autex Acoustics LLC

4136 Del Rey Ave
Marina Del Rey, CA 90292
United States of America
Phone **+1 (310) 490 1591**

www.autexacoustics.com